



### Descrizione

La composizione dell'insulation kit garantisce l'eliminazione delle correnti statiche che si creano tra due metalli con diverso potenziale elettrico, prevenendo la corrosione galvanica.

I materiali utilizzati per la realizzazione dei kit isolanti hanno come caratteristica peculiare la costante dielettrica elevata e la resistenza all'invecchiamento.

Questo kit include un Ring Joint in tessuto bachelizzato. La guarnizione è idonea per flange Ring Joint (RJ). Il kit comprende:

- una guarnizione (RJ) in tela bachelizzata: tessuto di cotone e resina fenolica. PTFE (vergine/strutturato), NEMA G11;
- un set di guaine isolanti in G10 o G11 per ogni tirante;
- una coppia di rondelle isolanti;

### Applicazioni

Indicato per l'accoppiamento tra diversi tipi di flangia al fine di ridurre al minimo la stagnazione del fluido, della turbolenza del flusso e dell'erosione tra le flange.

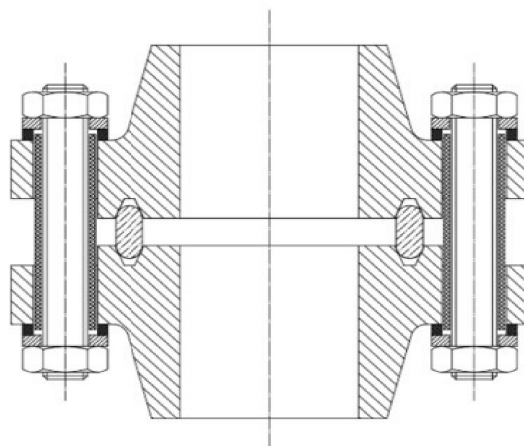

## Washer

Parametri	ASTM	Phenolic	G7	G10	G11
Rigidità dielettrica » Volts/mil	D149	500,000	350	800	550
Resistenza compressione » psi	D659	33	40	65	60,000+
Assorbimento idrico » %	D229	1,600	0,070	0,040	0,070
Temperatura » °C	-	-54 +104	-196 +232	-196 +150	-196 +200

## Sleeve

Parametri	ASTM	Mylar	Nomex	Phenolic	G10	G11
Rigidità dielettrica » Volts/mil	D149	4,000	400	400	400	400
Resistenza compressione » psi	D659	0,8	N/A	1,6	0,1	0,1
Assorbimento idrico » %	D229	13,000	20,000	16,000	55,000	55,000
Temperatura » °C	-	-59 +149	-54 +232	-54 +104	-196 +150	-196 +200

## Guarnizione

Parametri	ASTM	Tela Bacheliz-zata	Mica Rigida	G10	G11
Rigidità dielettrica » Volts/mil	D149	500	500	800	550
Resistenza compressione » psi	D659	25,000	25,000	65,000	60,000
Assorbimento idrico » %	D229	3	0,8	0,04	0,07
Resistenza elettrica » Meg.ohms	D257	40,000	40,000	200,000	200,000
Resistenza alla flessione » psi	D790	22,500	22,500	65,000	62,000
Resistenza alla trazione » psi	D638	20,000	20,000	51,000	42,500
Temperatura » °C	-	-54 +120	-35 +79	-196 +150	-196 +200





## Product Description:

The composition of the flange insulation kit guarantees the elimination of static currents created between two metals with different electrical potentials, preventing galvanic corrosion. The materials used to make the insulation kits are characterised by their high dielectric constant and resistance to ageing. This kit includes a Ring Joint made of bakelised fabric. The gasket is suitable for Ring Joint (RJ) flanges. The kit includes: a gasket (RJ) in bakelised fabric: cotton fabric and phenolic resin. PTFE (virgin/structured), NEMA G11; one set of

## Application:

Suitable for coupling between different flange types in order to minimise fluid stagnation, flow turbulence and erosion between flanges.

## Notice:

The operating temperature and pressure limits do not apply simultaneously; they depend on various factors and can only be indicated for guidance.

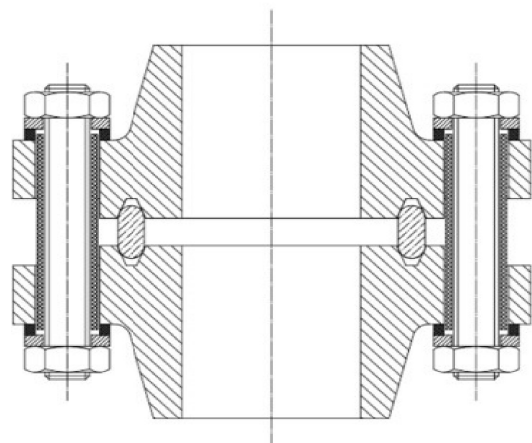

## Washer

Parameters	ASTM	Phenolic	G7	G10	G11
Dielectric strength » Volts/mil	D149	500,000	350	800	550
Compressive strength » psi	D659	33	40	65	60,000+
Water Absorption » %	D229	1,600	0,070	0,040	0,070
Temperatura » °C	-	-54 +104	-196 +232	-196 +150	-196 +200

## Sleeve

Parameters	ASTM	Mylar	Nomex	Phenolic	G10	G11
Dielectric strength » Volts/mil	D149	4,000	400	400	400	400
Compressive strength » psi	D659	0,8	N/A	1,6	0,1	0,1
Water Absorption » %	D229	13,000	20,000	16,000	55,000	55,000
Temperature » °C	-	-59 +149	-54 +232	-54 +104	-196 +150	-196 +200

## Gasket

Parameters	ASTM	Canvas	Mica Stiff	G10	G11
Dielectric strength » Volts/mil	D149	500	500	800	550
Compressive strength » psi	D659	25,000	25,000	65,000	60,000
Water Absorption » %	D229	3	0,8	0,04	0,07
Electrical resistance » Meg.ohms	D257	40,000	40,000	200,000	200,000
Flexural strength » psi	D790	22,500	22,500	65,000	62,000
Tensile strength » psi	D638	20,000	20,000	51,000	42,500
Temperature » °C	-	-54 +120	-35 +79	-196 +150	-196 +200

